

8" Ductile Iron Knife Gate Valve

2-Piece Body, EPDM Seat, Rising Stem

Split body ductile iron wafer knife gate valve with EPDM seat.

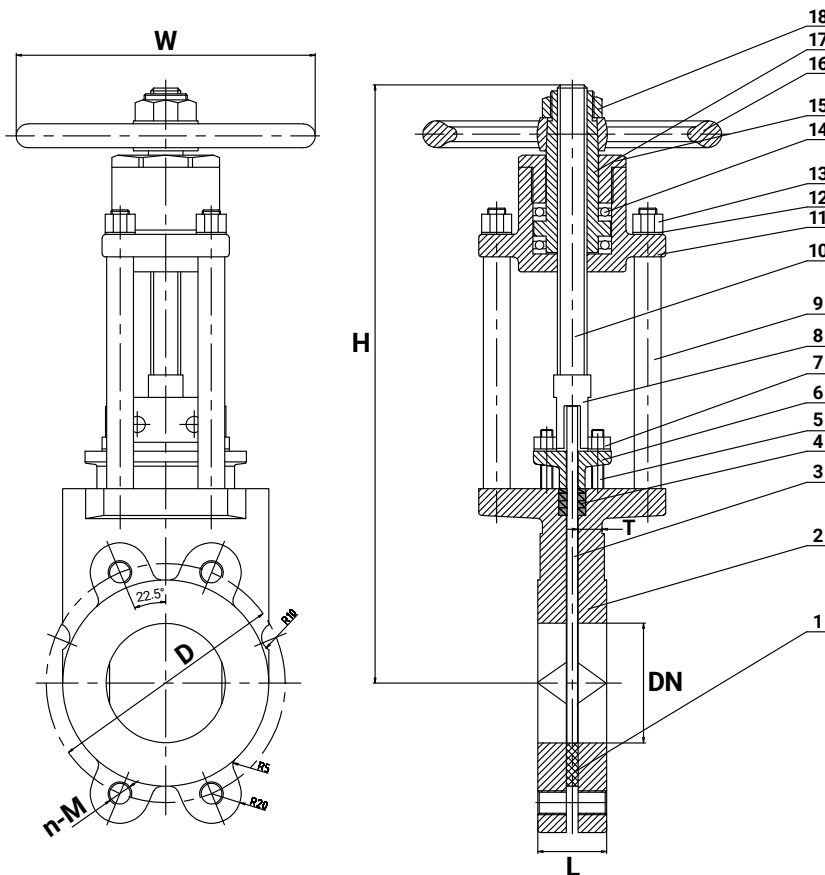

Dimensions

Size	DN	D		H		L		n-M		W		T	
in.	mm	in.	mm	in.	mm	in.	mm	in.	in.	mm	in.	mm	
2"	50	4 $\frac{1}{4}$	120.5	13 $\frac{1}{4}$	337	1 $\frac{1}{8}$	48	4- $\frac{5}{8}$ "	7 $\frac{1}{16}$	180	$\frac{1}{2}$	12.5	
3"	80	6	152.5	15 $\frac{3}{4}$	400	2	51	4- $\frac{5}{8}$ "	7 $\frac{7}{16}$	200	$\frac{9}{16}$	16	
4"	100	7 $\frac{1}{2}$	190.5	18 $\frac{5}{8}$	466	2	51	8- $\frac{5}{8}$ "	9 $\frac{1}{16}$	250	$\frac{9}{16}$	16	
6"	150	9 $\frac{1}{2}$	241.5	24 $\frac{15}{16}$	633	2 $\frac{1}{4}$	57	8- $\frac{3}{4}$ "	11 $\frac{13}{16}$	300	1 $\frac{1}{16}$	17	
8"	200	11 $\frac{1}{4}$	298.5	29 $\frac{9}{16}$	744	2 $\frac{3}{4}$	70	8- $\frac{3}{4}$ "	13 $\frac{3}{4}$	350	1 $\frac{1}{16}$	18	
10"	250	14 $\frac{1}{4}$	362	37	940	2 $\frac{3}{4}$	70	12- $\frac{7}{8}$ "	15 $\frac{3}{4}$	400	1 $\frac{1}{16}$	18	
12"	300	17	432	42 $\frac{13}{16}$	1087	3	76	12- $\frac{7}{8}$ "	19 $\frac{11}{16}$	500	1 $\frac{1}{16}$	18	

Size	8"
Design Standard	MSS SP-81
Stem	Rising Stem
Operator	Handwheel
Connections	Flange / ANSI 125
Pressure Rating	150 PSI
Temperature Rating	-4° to 185° F
Length (End to End)	2.8"
Weight	111 lbs

Features

- Split Body Design
- Rising Stem
- EPDM Seat

Materials List

No.	Part Name	Material	Qty
1	U-Ring	EPDM	1
2	Body	Ductile Iron	2
3	Knife	SS304	1
4	Packing	PTFE	
5	Stud	Stainless Steel	4
6	Packing Gland	Ductile Iron	1
7	Nut	Stainless Steel	4
8	Link Block	SS304	1
9	Yoke	Stainless Steel	4
10	Stem	SS420	1
11	Bearing Box	Ductile Iron	1
12	Washer	Stainless Steel	4
13	Nut	Stainless Steel	4
14	Thrust Bearing	Steel	2
15	Gland	Ductile Iron	1
16	Handwheel	Ductile Iron	1
17	Stem Nut	Brass	1
18	Nut	Ductile Iron	1