

3" Cast Iron Gate Valve Metal Seated, Non-Rising Stem

Cast iron gate valve with cast bronze seat and non-rising stem.

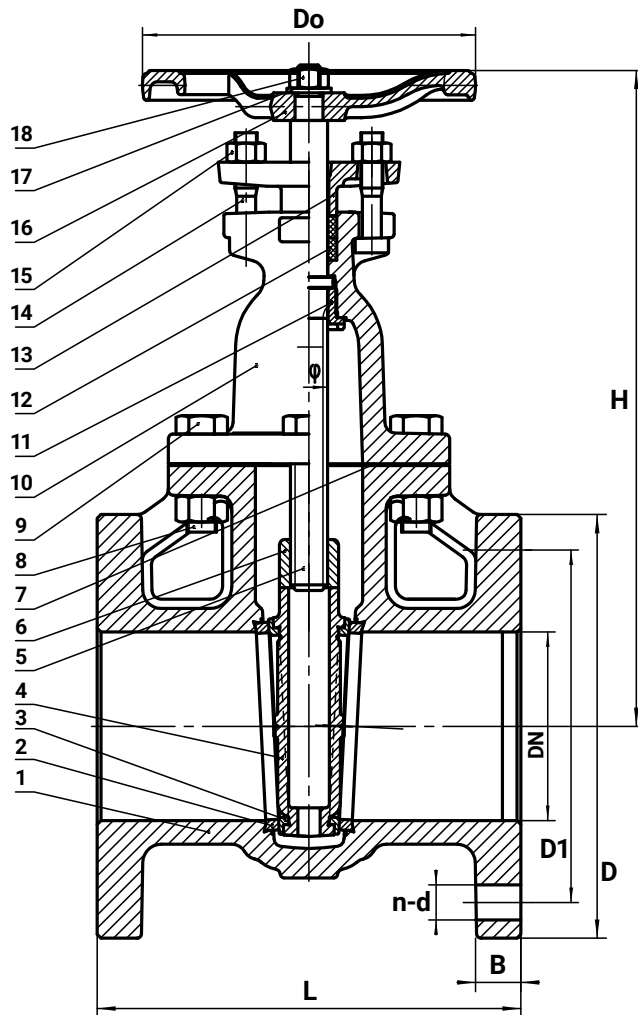

Size	3"
Design Standard	MSS SP-70
Stem	Non-Rising Stem
Operator	Handwheel
Connections	Flanged / ANSI 125
Length (End to End)	8"
Weight	52 lbs

Features

- Suitable for Water, Oil & Steam
- Non-Rising Stem
- Solid Wedge
- Flanges Conform to ANSI B16.1

Materials List

No.	Part Name	Material
1	Body Seat Ring	Cast Iron ASTM A 126-B
2	Body Seat Ring	Cast Bronze ASTM B62
3	Wedge Seat Ring	Cast Bronze ASTM B62
4	Wedge	Cast Iron ASTM A 126-B
5	Stem	Stainless Steel SS420
6	Stem Nut	Cast Brass
7	Gasket	Graphite Non-Asbestos
8	Bolt	Steel
9	Nut	Steel
10	Bonnet	Cast Iron ASTM A 126-B
11	Bonnet Bush	Cast Brass
12	Packing	Graphite Non-Asbestos
13	Gland Follower	Ductile Iron ASTM A 536 60-40-18
14	Bolt	Steel
15	Nut	Steel
16	Handwheel	Cast Iron ASTM A 126-B
17	Washer	Steel
18	Handwheel Nut	Steel

Dimensions

Size	L		D		D1		n-d		B		Do		H	
in.	in.	mm	in.	mm	in.	mm	mm (in.)	in.	mm	in.	mm	in.	mm	
2"	7	177.8	6	152	4 ³ / ₄	121	4-19 (3/4)	9/16	15.9	7 ¹ / ₁₆	180	9 ⁷ / ₁₆	240	
3"	8	203	7 ¹ / ₂	190	6	153	4-19 (3/4)	3/4	19.1	7 ⁷ / ₁₆	200	12 ¹¹ / ₁₆	323	
4"	9	229	9	229	7 ¹ / ₂	191	8-19 (3/4)	1 ¹ / ₁₆	23.9	10	254	14 ³ / ₁₆	365	
6"	10 ¹ / ₂	267	11	279	9 ¹ / ₂	242	8-22 (7/8)	1	25.4	11 ¹³ / ₁₆	300	18 ³ / ₁₆	477	
8"	11 ¹ / ₂	292	13 ¹ / ₂	343	11 ³ / ₄	299	8-22 (7/8)	1 ¹ / ₈	28.6	11 ¹³ / ₁₆	300	23 ¹⁵ / ₁₆	585	
10"	13	330	16	406	14 ¹ / ₄	362	12-25 (1)	1 ³ / ₁₆	30.2	13 ³ / ₄	350	27 ¹⁵ / ₁₆	710	
12"	14	356	19	483	17	432	12-25 (1)	1 ¹ / ₄	31.8	15 ³ / ₄	400	31 ¹ / ₁₆	789	