

8" Ductile Iron Gate Valve

Resilient Seated, Rising Stem

Ductile iron gate valve with epoxy coating and EPDM covered ductile iron wedge for positive seating and resistance to high differential pressure.

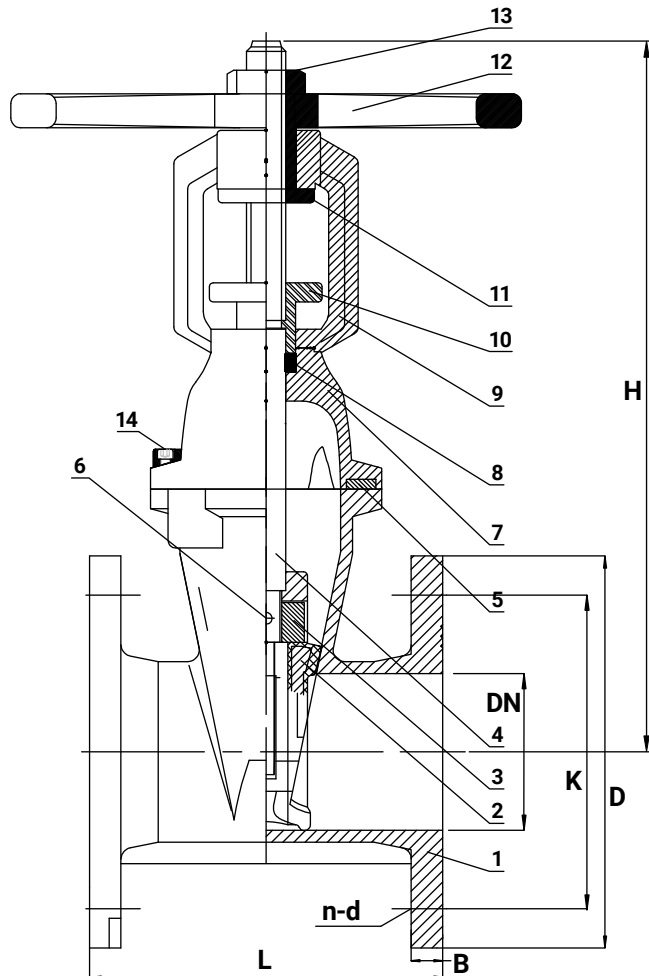

Size	8"
Design Standard	AWWA C515
Stem	Rising Stem
Operator	Handwheel
Connections	Flanges / ANSI 125
Pressure Rating	250 PSI
Temperature Rating	-4° to 212° F
Length (End to End)	11.5"
Weight	164 lbs

Features

- Rising Stem
- Resilient Wedge
- Fusion Bonded Epoxy Coated Interior and Exterior to AWWA C550 Standard
- Flanges Conform to ANSI B16.1

Materials List

No.	Part Name	Material
1	Body	GGG50
2	Disc	GGG50+EPDM
3	Stem Nut	Brass
4	Stem	2CR13
5	Gasket	EPDM
6	Pin	Carbon Steel
7	Bonnet	GGG50
8	Packing	Polyurethane
9	Yoke	GGG50
10	Pressing Plate	GGG50
11	Nut	GGG50
12	Handwheel	GGG50
13	Locking Nut	Carbon Steel
14	Bolts	Carbon Steel

Dimensions

Size	DN	L	D	K	B	n-d	H
in.	mm	in.	mm	in.	mm	mm (in.)	in.
2"	50	7 178	6 152	4 ³ / ₄ 120.5	5 ¹ / ₈ 16	4-19 (3/4)	10 ¹ / ₁₆ 255
3"	80	8 203	7 ¹ / ₂ 191	6 152.5	5 ¹ / ₈ 19	4-19 (3/4)	13 ⁹ / ₁₆ 345
4"	100	9 229	9 229	7 ¹ / ₂ 190.5	15 ¹ / ₁₆ 24	8-19 (3/4)	16 ⁹ / ₁₆ 420
6"	150	10 ¹ / ₂ 267	11 279	9 ¹ / ₂ 241.5	1 26	8-22 (7/8)	20 ¹ / ₁₆ 510
8"	200	11 ¹ / ₂ 292	13 ¹ / ₂ 343	11 ¹ / ₄ 298.5	1 ¹ / ₈ 28	8-22 (7/8)	27 ¹⁵ / ₁₆ 710
10"	250	13 330	16 406	14 ¹ / ₄ 362.5	1 ³ / ₁₆ 30	12-25 (1)	31 ¹ / ₁₆ 795
12"	300	14 356	19 483	17 432	1 ¹ / ₄ 32	12-25 (1)	37 ³ / ₈ 950