

4" Cast Iron Globe Valve Metal Seated

Cast iron globe valve with cast bronze seat.

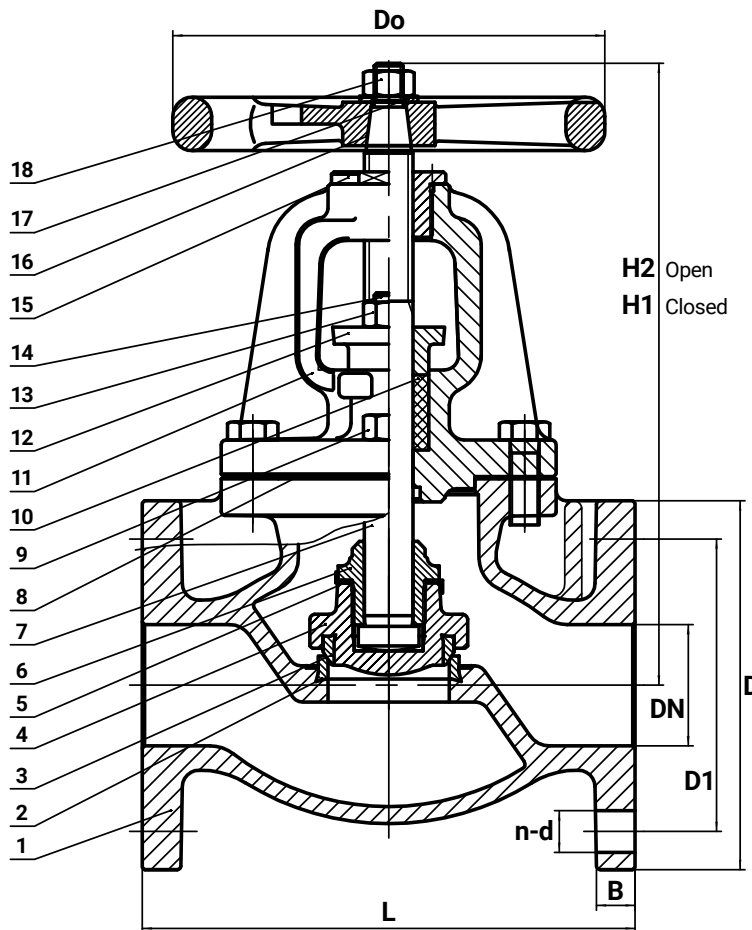

Size	4"
Design Standard	MSS SP-85
Connections	Flanged / ANSI 125
Operator	Handwheel
Pressure Rating	200 PSI @ -20° to 150° F 125 PSI @ 450° F
Length (End to End)	11.5"
Weight	104 lbs

Features

- Suitable for Water, Oil & Steam
- Flanges Conform to ANSI B16.1

Dimensions

Size	L		D		D1		B		n-d		Do		H1		H2	
in.	in.	mm	in.	mm	in.	mm	in.	mm	mm (in.)	in.	mm	in.	mm	in.	mm	
2"	8	203	6	152	4 ³ / ₄	121	5 ¹ / ₈	15.9	4-19 (3/4)	7	178	10 ¹ / ₁₆	256	10 ¹³ / ₁₆	274	
3"	9 ¹ / ₂	241	7 ¹ / ₂	190	6	153	3 ¹ / ₄	19.1	4-19 (3/4)	7 ⁷ / ₈	200	12 ¹¹ / ₁₆	323	13 ³ / ₈	353	
4"	11 ¹ / ₂	292	9	229	7 ¹ / ₂	191	1 ⁵ / ₁₆	23.9	8-19 (3/4)	10	254	14 ³ / ₈	365	15 ⁷ / ₈	403	
6"	14	356	11	279	9 ¹ / ₂	242	1	25.4	8-22 (7/8)	11 ¹ / ₈	300	18 ⁵ / ₈	472	20 ¹ / ₁₆	529	
8"	19 ¹ / ₂	495	13 ¹ / ₂	343	11 ³ / ₄	299	1 ¹ / ₈	28.6	8-22 (7/8)	13 ³ / ₄	348	21	533	23 ¹ / ₁₆	605	

Materials List

No.	Part Name	Material
1	Body	Cast Iron ASTM A 126-B
2	Body Seat Ring	Cast Bronze ASTM B 62
3	Disc Seat Ring	Cast Bronze ASTM B 63
4	Disc Seat Ring	Cast Iron ASTM A 126-B
5	Washer	Stainless Steel ASTM 304
6	Disc Nut	Cast Brass
7	Stem	Stainless Steel SS420
8	Gasket	Graphite Non-Asbestos
9	Bolt	Steel ASTM A 307-B
10	Packing	Graphite Non-Asbestos
11	Bonnet	Cast Iron ASTM A 126-B
12	Packing Gland	Ductile Iron ASTM A536 65-45-12
13	Nut	Steel
14	Bolt	Steel
15	Stem Nut	Cast Brass
16	Handwheel	Cast Iron ASTM A 126-B
17	Washer	Steel
18	Nut	Steel ASTM A 563-B