

8" Ductile Iron Gate Valve

Resilient Seated, Non-Rising Stem

Ductile iron gate valve with epoxy coating and EPDM covered ductile iron wedge for positive seating and resistance to high differential pressure.

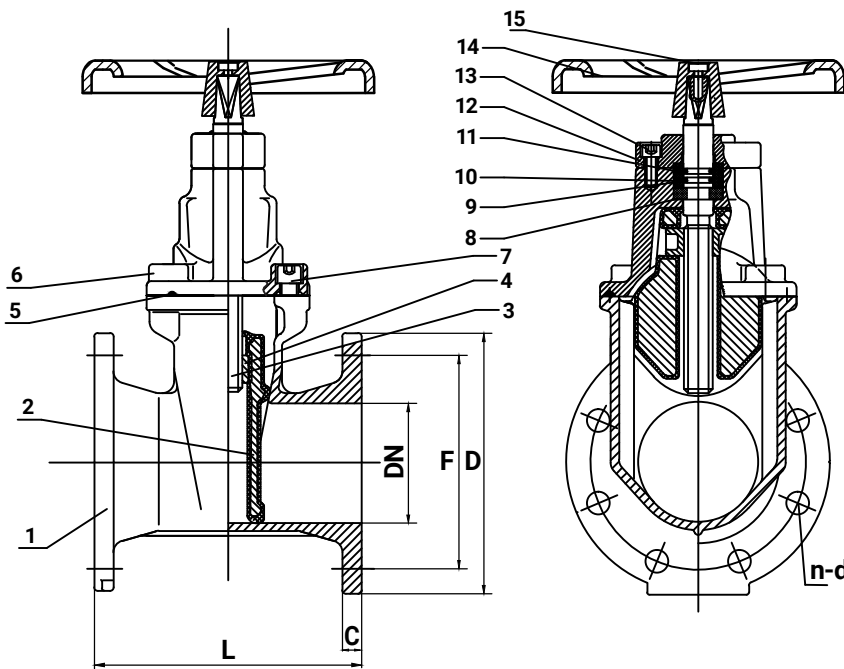

Size	8"
Design Standard	AWWA C515
Stem	Non-Rising Stem
Operator	Handwheel
Connections	Flanges / ANSI 125
Pressure Rating	250 PSI
Temperature Rating	180° F
Length (End to End)	11.5"
Weight	138 lbs

Features

- Non-Rising Stem
- Resilient Wedge
- Fusion-Bonded Epoxy Coating Inside & Outside
- Flanges Conform to ANSI B16.1

Dimensions

Size	DN	L		D		F		C		n-d
in.	mm	in.	mm	in.	mm	in.	mm	in.	mm	mm (in.)
2"	50	7	178	5 ⁷ / ₈	150	4 ³ / ₄	120.5	5 ¹ / ₈	15.9	4-19 (3/4)
3"	80	8	203	7 ¹ / ₂	190	6	152.5	3 ³ / ₄	19.1	4-19 (3/4)
4"	100	9	229	9	229	7 ¹ / ₂	190.5	1 ⁵ / ₁₆	23.9	8-19 (3/4)
6"	150	10 ¹ / ₂	267	11	279	9 ¹ / ₂	241.5	1	25.4	8-22 (7/8)
8"	200	11¹/₂	292	13¹/₂	343	11³/₄	298.5	1¹/₈	28.6	8-22 (7/8)
10"	250	13	330	16	406	14 ¹ / ₄	362.5	1 ¹ / ₁₆	30.2	12-25 (1)
12"	300	14	356	19	483	17	432	1 ¹ / ₄	31.8	12-25 (1)

Materials List

No.	Part Name	Material
1	Body	GGG50
2	Disc	GGG50+EPDM
3	Stem	SS420
4	Stem Nut	Brass
5	Gasket	EPDM
6	Bonnet	GGG50
7	Bolts	Carbon Steel
8	Holding Ring	Brass
9	O-Ring	NBR
10	O-Ring	NBR
11	Seal Cartridge	POM
12	Gland	GGG50
13	Bolts	Carbon Steel
14	Handwheel	GGG50
15	Bolt	SS304